

Air Pump

HYDRAULIC PA60 SERIES

6 cu. in./min.
Two-Speed

Two-speed pump for rapid oil delivery at low pressure quickly advances cylinder or tool.

PUMPS

- Equipped with air pressure regulator, air filter and lubricator.
- Serviceable air motor for economical repair.
- Internal relief valve protects circuit components.
- Permanently vented reservoir cap.



The PA60 used in a workholding environment.

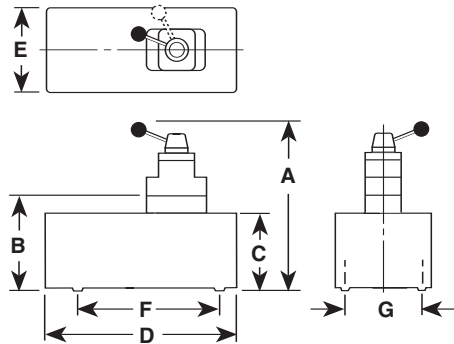

Pump No.	A (in.)	B (in.)	C (in.)	D (in.)	E (in.)	F (in.)	G (in.)	Max. Pressure Output (psi)	Oil Del. * (cu. in./min. @)				
									0 (psi)	100 (psi)	1,000 (psi)	5,000 (psi)	10,000 (psi)
PA60	—	9 ⁷ / ₁₆	8 ³ / ₈	14 ¹ / ₄	9 ⁵ / ₈	7 ¹ / ₈	5 ¹ / ₈	10,000	390	350	50	12	6
PA64	14 ¹ / ₄	—	8 ³ / ₈	14 ¹ / ₄	9 ⁵ / ₈	7 ¹ / ₈	5 ¹ / ₈	10,000	390	350	50	12	6

* Typical delivery. Actual flow will vary with field conditions.

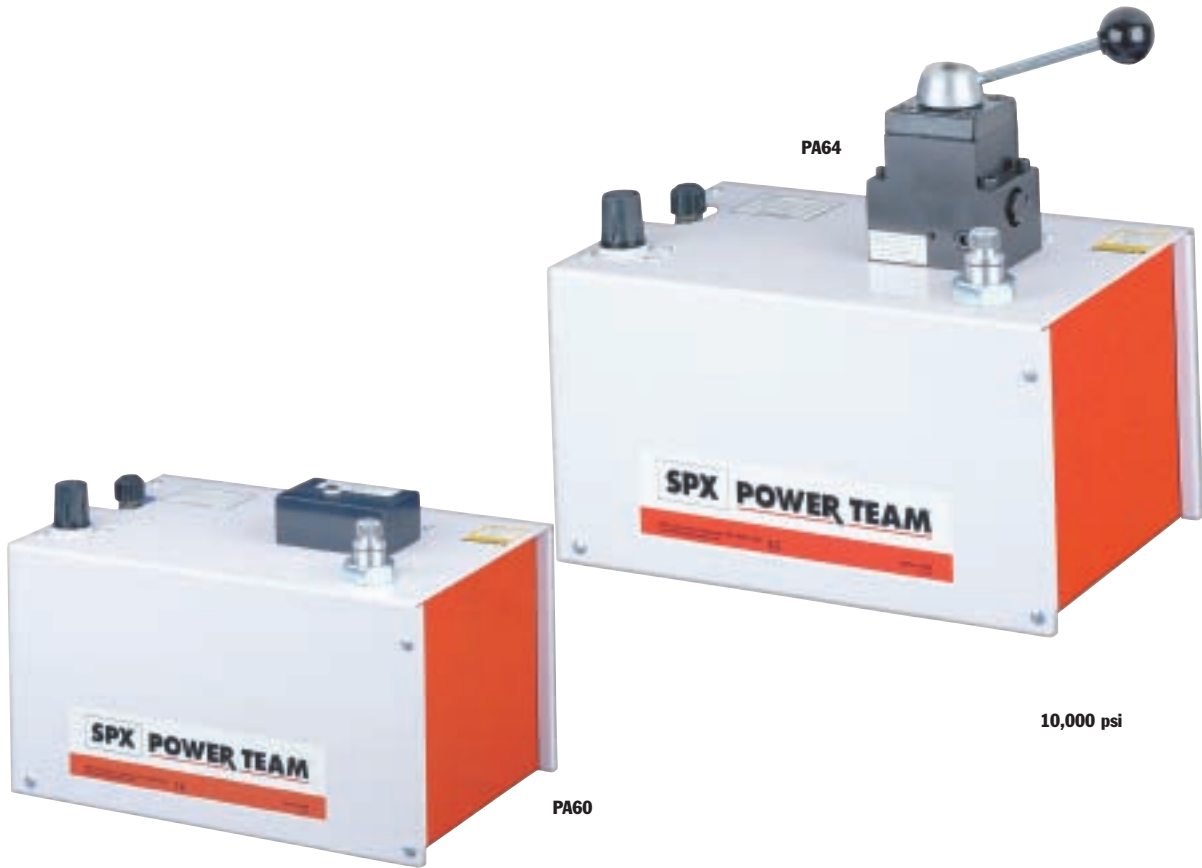

10,000 psi

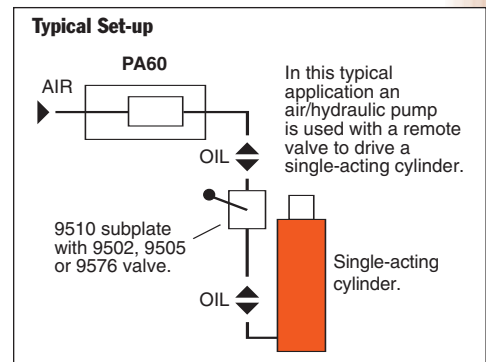
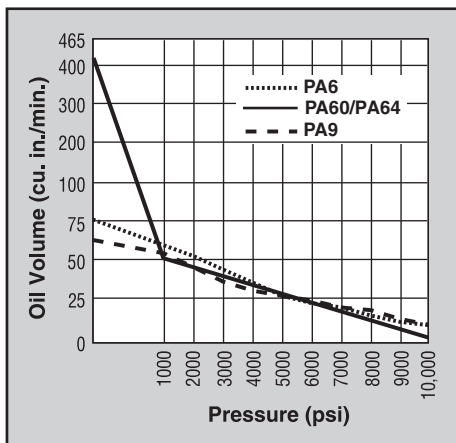

Description	Order No.	Valve No.	Valve Function	Air Supply	Reservoir		Oil Port (in.)	Prod. Wt (lbs.)
				Req'd (psi)	Cap. (gal.)	Usable (cu. in.)		
For use with remote valves.	PA60	Manifold	—	40-120	2	425	3/8 NPTF	54
For use with single- or double-acting cylinders.	PA64	9507, 3-way/ 4-way	Advance Hold Return	40-120	2	425	3/8 NPTF	56

Notes: Air inlet port 1/4" NPTF. Requires 20 cfm at 100 psi shop air pressure at the pump.

