

# Air Pump

## HYDRAULIC PA50 SERIES

**28 cu. in./min.**  
Low Pressure

Single-speed, low pressure  
(3,200 psi) output pumps.

PUMPS

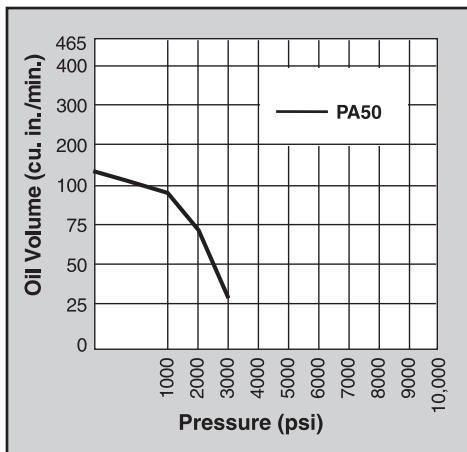

PA50D



PA50M

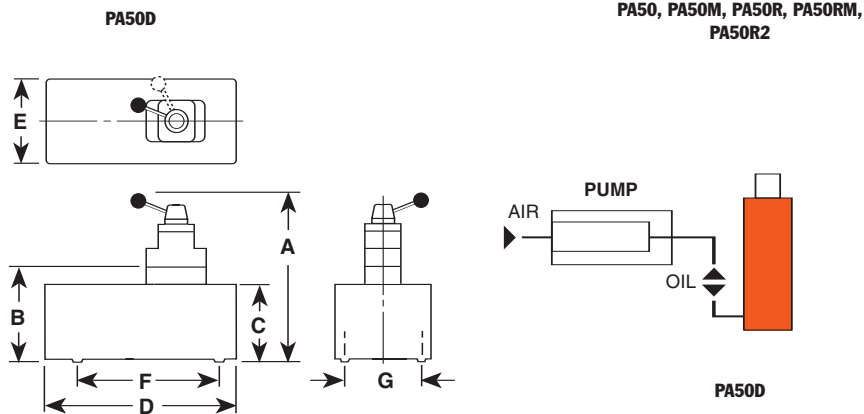

Pump No.	A (in.)	B (in.)	C (in.)	D (in.)	E (in.)	F (in.)	G (in.)	Max. Pressure Output (in.)	Oil Del. * (cu. in./min. @)					
									0 (psi)	100 (psi)	1,000 (psi)	5,000 (psi)	10,000 (psi)	
<b>PA50, PS50R</b>														
<b>PA50M, PA50RM</b>	7 <sup>3</sup> / <sub>4</sub>	5 <sup>7</sup> / <sub>8</sub>	4 <sup>3</sup> / <sub>8</sub>	9 <sup>1</sup> / <sub>2</sub>	5	—	4 X 9	3,200	128	110	88	28 †	—	
<b>PA50R2</b>	10 <sup>1</sup> / <sub>4</sub>	8	7	11 <sup>1</sup> / <sub>2</sub>	9 <sup>1</sup> / <sub>2</sub>	—	5 <sup>1</sup> / <sub>8</sub> X 7 <sup>1</sup> / <sub>8</sub>	3,200	128	110	88	28 †	—	
<b>PA50D</b>	10 <sup>3</sup> / <sub>8</sub>	5 <sup>7</sup> / <sub>8</sub>	4 <sup>3</sup> / <sub>8</sub>	9 <sup>1</sup> / <sub>2</sub>	5	9	4	3,200	128	110	88	28 †	—	

\* Typical delivery. Actual flow will vary with field conditions.

† PA50 Series measured at 3,200 psi.

- Serviceable air motor for economical repair.
- Air inlet filter protects motor. Filter in outlet port protects against contaminated systems.
- Assorted reservoirs to suit your application's requirements.

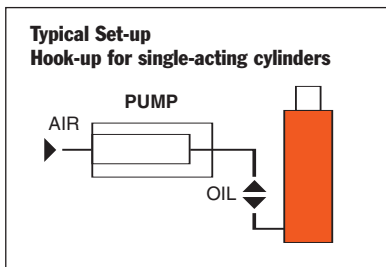

For use with Cyl. Type	Description	Order No.	Valve No.	Air Supply Req'd (psi)	Reservoir			Prod. Wt (lbs.)
					Cap. (cu. in.)	Usable (cu. in.)	Oil Port (in.)	
Single-Acting	Base model pump with high density polyethylene reservoir.	<b>PA50</b>	—	40-120	105	98	3/8 NPTF	14.2
Single-Acting	PA50, except has metal reservoir.	<b>PA50M</b>	—	40-120	105	98	3/8 NPTF	16.2
Single-Acting	PA50, except has 12 foot remote control.	<b>PA50R</b>	—	40-120	105	98	3/8 NPTF	18.5
Single-Acting	PA50, except has metal reservoir.	<b>PA50RM</b>	—	40-120	105	98	3/8 NPTF	20.5
Single-Acting	PA50R, except has 2 gallon reservoir.	<b>PA50R2</b>	—	40-120	2 gal.	454	3/8 NPTF	28.5
Single- and Double Acting	PA50, except designed to operate either single- or double-acting systems. Valve function: Advance / Return.	<b>PA50D</b>	9504, 3-way/ 4-way	40-120	105	98	3/8 NPTF	18.4

**Notes:** Air inlet port 1/4" NPTF. Requires 20 cfm at 100 psi shop air pressure at the pump.

