

Electric Pump

HYDRAULIC PE55 VANGUARD®

55 cu. in./min.
For cylinders up to 200 tons.

Heavy duty multiple-applications pump. Heavy construction and concrete stressing. Low voltage starting possible.

PUMPS

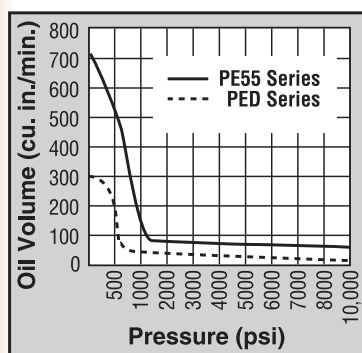

- 1¹/₈ hp, 12,000 rpm, 110/115 volt, 50/60 Hz universal motor; draws 25 amps at full load, starts at reduced voltage. CSA rated for intermittent duty.
- 10 foot remote motor control (except PE552S which has a 25 foot remote motor and valve control).
- True unloading valve achieves greater pump efficiency, allowing higher flows at maximum pressure.
- Reservoirs available in sizes up to 10 gallons. See accessories page 109.
- Light weight and portable. Best weight to performance ratio of all Power Team pumps.
- “Assemble to Order” System: There are times when a custom pump is required. Power Team’s “Assemble to Order” system allows you to choose from a wide range of pre-engineered, off-the-shelf components to build a customized pump to fit specific requirements. By selecting standard components you get a “customized” pump without “customized” prices. All pumps come fully assembled, less oil and ready for work. See pages 102-105.



PE554W
The new pump;
weather-resistant.



PE55TWP
Torque Wrench
Applications
See page 162

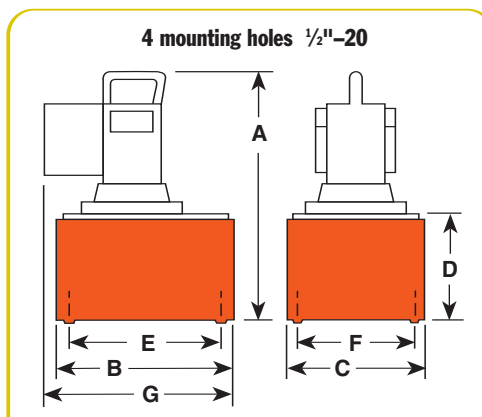

Pump No.	Max. Pressure Output (psi)	rpm	dBa at Idle and 10,000 (psi)	Amp Draw at 10,000 psi (115 V)**	Oil Del. (cu. in./min. @)				A (in.)	B (in.)	C (in.)	D (in.)	E (in.)	F (in.)	G (in.)	H (in.)	Prod. Wt. w/Oil (lbs.)
					0 (psi)	700 (psi)	5,000 (psi)	10,000 (psi)									
PE55 Series	10,000	12,000	90/89*	25	704	440	74	56	18 ¹ / ₄	11 ¹ / ₂	9 ¹ / ₂	7	10	8	14	-	65

*Noise level reading (dBA) measured at a 3 ft. distance, all sides.

** Amp draw at 10,000 psi, 230 Volts 50/60 Hz is 15 Amps.



PE554S



PE554PT



PE552

10,000 psi



For use with Cyl. Type	Description	Order No.***	Valve Type	Valve No.	Valve Function	Control Switch††	Motor	Reservoir Usable (cu. in.)
Single-Acting	Base model 1 ¹ / ₈ hp pump with 2 ¹ / ₂ gal. reservoir, remote motor control & 3-way valve.	PE552	3-Way	9582	Advance Return**	Remote Motor	1 ¹ / ₈ hp*, 110/115 VAC 50/60 Hz, Single Phase	525
Single-Acting	PE552, except also has solenoid operated remote valve.	PE552S	3-Way	9579	Advance Hold Return	Remote Motor & Valve	1 ¹ / ₈ hp*, 110/115 VAC 50/60 Hz, Single Phase	525
Single-Acting	PE552, except has "Auto Dump" valve.	PE552A∞	Auto/Dump	9610	Advance Return	Remote Motor	1 ¹ / ₈ hp*, 110/115 VAC 50/60 Hz, Single Phase	525
Single-Acting	1 ¹ / ₈ hp pump with 2 ¹ / ₂ gal. reservoir. Valve has "Posi-check" feature.	PE553	3-Way†	9520	Advance Hold Return	Remote Motor	1 ¹ / ₈ hp*, 110/115 VAC 50/60 Hz, Single Phase	525
Double-Acting	Base model 1 ¹ / ₈ hp pump with 2 ¹ / ₂ gal. res. and 4-way valve for double-acting systems.	PE554	4-Way†	9506	Advance Hold Return	Remote Motor	1 ¹ / ₈ hp*, 110/115 VAC 50/60 Hz, Single Phase	525
Double-Acting	Weather-resistant model 1 ¹ / ₈ hp pump with 2 ¹ / ₂ gal. res. and 4-way valve for double-acting systems.	PE554W	4-Way†	9506	Advance Hold Return	Remote Motor	1 ¹ / ₈ hp*, 110/115 VAC 50/60 Hz, Single Phase	525
Double-Acting	PE554, except has 9500 tandem center valve.	PE554T	4-Way	9500	Advance Hold Return	Remote Motor	1 ¹ / ₈ hp*, 110/115 VAC 50/60 Hz, Single Phase	525
Double-Acting	For use with single-acting Spring Seat, Stressing Jack or double-acting cylinder.	PE554P	4-Way	9500	Advance Hold Return	Remote Motor	1 ¹ / ₈ hp*, 110/115 VAC 50/60 Hz, Single Phase	525
Double-Acting	For use with single-acting or double-acting Power Seat, Stressing Jacks ONLY.	PE554PT	4-Way	9628	Advance Hold Sequenced Return	Remote Motor	1 ¹ / ₈ hp*, 110/115 VAC 50/60 Hz, Single Phase	525
Double-Acting	Pump suitable to run multiple spring return tools.	PE554C	4-Way	9511†††	Advance Hold Return	Remote Motor	1 ¹ / ₈ hp*, 110/115 VAC 50/60 Hz, Single Phase	525
Double-Acting	Pump equipped with 3/4-way solenoid valve.	PE554S	3/4-Way	9592	Advance Hold Return	Remote Motor & Valve	1 ¹ / ₈ hp*, 110/115 VAC 50/60 Hz, Single Phase	525

* Pumps available with 230 volt, 60/50 Hz motors. Specify voltage when ordering. See "Assemble to Order" pump options on pages 102-105.

** Holds with motor shut off.

*** To order PE55 series pumps with CSA approval, add "-C" to the Order No.

† Valves have "Posi-Check®" feature.

†† Control switch wired with line voltage. All remotes are 10 ft. long except for PE552S which is 25 ft. long.

††† Valving allows alternate and independent operation of two different spring return tools. Valve holds pressure only while valve is in "A" or "B" port position with pump motor shut off.

∞ Not to be used for lifting.

