

# Portable HIGH TONNAGE

## 55, 100 & 150 Ton

Portable and compact, ideal for locomotive/railcar, mining and heavy equipment maintenance.

JACKS

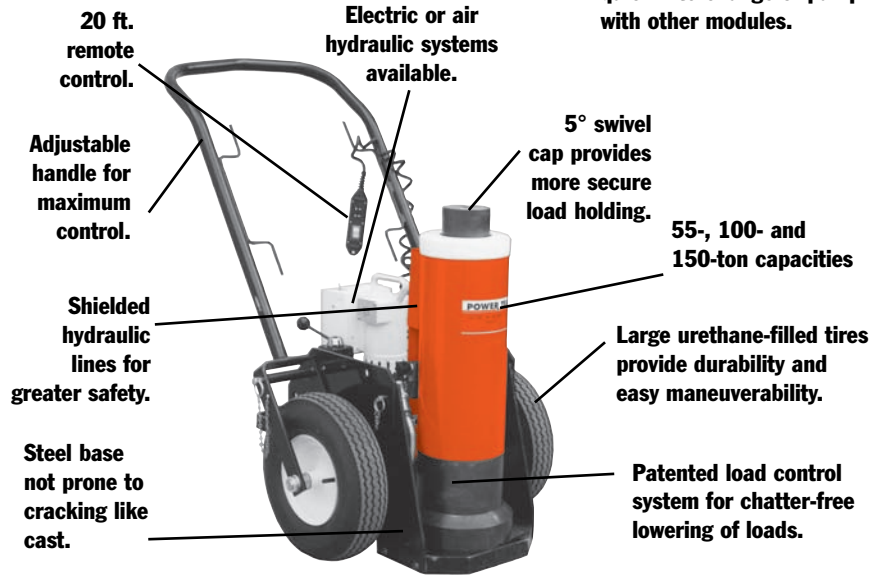

Modular design allows for quick interchange of pump with other modules.

- Modular design - pump and cart separate from cylinder and base.
- Three tonnage capacity options - 55-ton, 100-ton and 150-ton.
- Three collapsed height options - 26", 33" and 45".
- Two standard power options - air (PA55) and electric (PE55).
- Two control options - remote motor control and remote valve/motor control.
- Accessory options - 6<sup>5</sup>/<sub>8</sub>" extension, load-holding rings.
- Select the collapsed height to fit your most frequent application - add jacking modules to suit your needs.
- Remote operation for maximum operator safety and control - choose "motor only" or "motor and valve" control in the hand.
- Easy to maneuver - large tires and small "footprint" make it easy to scoot into the tightest quarters, then locate the exact lifting position.
- Adjustable, heavy-duty handle - makes this jack easy to move, position under vehicles. Can also be used to transport jack on site with a forklift.
- Load-holding rings (optional) - provide full rated mechanical load-holding capability.
- Cylinder extension (optional) - adds more versatility by extending your jack's reach.
- Low-temperature oil (optional) - provides smooth, reliable operation in the coldest climate conditions.
- Modular design - allows you to change lifting modules to suit your tonnage or height requirements. Use the pump module as a portable power station for your other double-acting cylinders (10,000 psi).
- Exclusive load-control system - provides positive, chatter-free control when lowering the load.
- Shielded and sheltered hydraulic lines - for safer, longer, trouble-free service.

### ORDER INFORMATION

#### CRIBBING BLOCK SETS - INCLUDES ONE JACK MODULE EXTENSION

Order No.‡	55 Ton CBS55		100 Ton CBS100		150 Ton CBS150	
	No. in Set		No. in Set		No. in Set	
A	1	3"	1	3"	1	3"
B	1	3 <sup>3</sup> / <sub>4</sub> "	1	3 <sup>3</sup> / <sub>4</sub> "	1	3 <sup>3</sup> / <sub>4</sub> "
C	1	5 <sup>1</sup> / <sub>2</sub> "	1	7 <sup>3</sup> / <sub>8</sub> "	1	8 <sup>3</sup> / <sub>4</sub> "
Jack Module Ext.	6 <sup>13</sup> / <sub>16</sub> "		7"		6 <sup>5</sup> / <sub>8</sub> "	
Total Stack Ht.	20 <sup>7</sup> / <sub>16</sub> "		20 <sup>1</sup> / <sub>2</sub> "		20 <sup>1</sup> / <sub>8</sub> "	
Product Wt. (lbs.)	36		68		85	

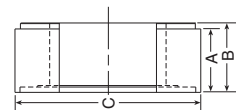

- Convert jack module into stable mechanical cribbing device.
- Increase retracted height up to 20<sup>1</sup>/<sub>2</sub> inches.

### ORDER INFORMATION

#### JACK MODULE EXTENSIONS

(tons)	No.	A (in.)	B (in.)	C (in.)	D (in.)	E (in.)	F (in.)	G (in.)	H (in.)	Prod. Wt. (lbs.)
55	<b>58945</b>	8 <sup>13</sup> / <sub>16</sub>	6 <sup>13</sup> / <sub>16</sub>	5	2 <sup>5</sup> / <sub>8</sub>	1 <sup>11</sup> / <sub>16</sub> -8UN	2 <sup>1</sup> / <sub>2</sub>	2 <sup>5</sup> / <sub>8</sub>	3 <sup>5</sup> / <sub>8</sub>	21
100	<b>58943</b>	9	7	6 <sup>7</sup> / <sub>8</sub>	3 <sup>7</sup> / <sub>8</sub>	2 <sup>3</sup> / <sub>4</sub> -12UN	3 <sup>3</sup> / <sub>4</sub>	3 <sup>7</sup> / <sub>8</sub>	3 <sup>3</sup> / <sub>4</sub>	40
150	<b>58944</b>	8 <sup>5</sup> / <sub>8</sub>	6 <sup>5</sup> / <sub>8</sub>	8	4 <sup>1</sup> / <sub>2</sub>	3 <sup>1</sup> / <sub>4</sub> -8UNC	4 <sup>3</sup> / <sub>8</sub>	4 <sup>1</sup> / <sub>2</sub>	3 <sup>1</sup> / <sub>2</sub>	50

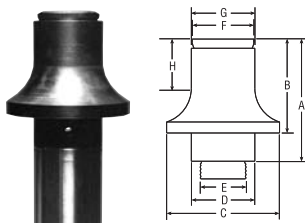

- Increases jack's reach.
- Swivel cap (5° max.) provides more secure load holding.

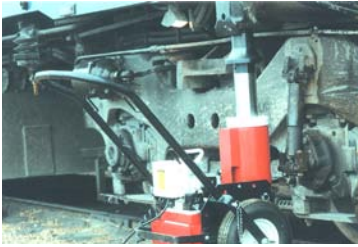

### Pump & cart modules

Pump and cart modules contain hydraulic pump, cart, remote control and all hoses and fittings required to connect to a jack module. Jack modules easily separate from the pump and cart module. Extra jack modules may be purchased for a wide variety of lifting applications.

Remote Control		
Pump	Motor Only	Motor & Valve
Air	PMA55	PMA55S
Electric	Consult Factory	PME55S

### Jack modules

Additional Jack Modules may be purchased for varying applications.

Collapsed Height				
Tonnage	Cylinder Stroke	26"	33"	45"
55	13 <sup>1</sup> / <sub>8</sub> "	JM25	JM35	JM45
100	13 <sup>3</sup> / <sub>8</sub> "	JM210	JM310	JM410
150	18 <sup>1</sup> / <sub>8</sub> "	JM215	JM315	JM415
200	18 <sup>3</sup> / <sub>8</sub> "	JM220	JM320	JM420



Air pump and cart module.



Electric pump and cart module.



26" Jack Module



33" Jack Module



45" Jack Module

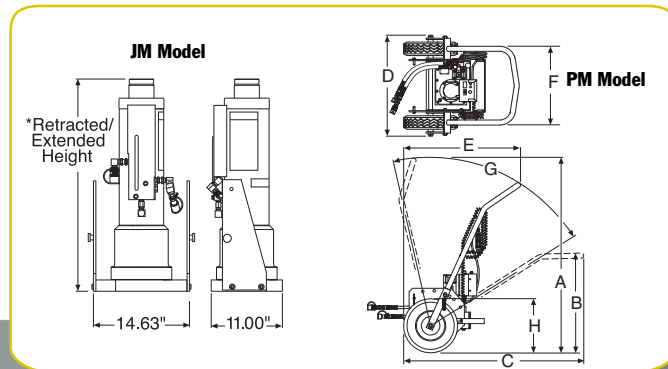

### Dimensions

Model Series	A	B	C	D	E	F	G	H
<b>PMA &amp; PME</b>	57 <sup>5</sup> / <sub>8</sub> "	29 <sup>5</sup> / <sub>8</sub> "	53 <sup>1</sup> / <sub>4</sub> "	30"	34 <sup>5</sup> / <sub>16</sub> "	23 <sup>3</sup> / <sub>8</sub> "	*70°	16" Tire Dia.

\* Total range with varying degree increments.

### ORDER INFORMATION – Pump and Cart Modules with Assembled Jack Module

Capacity (tons)	Ret. Height (in.)	Ext. Height (in.)	Stroke (in.)	Pump Type	Power Required	Valve Type	Remote Control	Order No.
55	26	39 <sup>1</sup> / <sub>8</sub>	13 <sup>1</sup> / <sub>8</sub>	Electric	25 amps	Manual	M	<b>JEM5526</b>
100	33	46 <sup>1</sup> / <sub>8</sub>	13 <sup>3</sup> / <sub>8</sub>	Air	50 CFM @ 80 psi	Manual	M	<b>JAM10033</b>
100	33	46 <sup>1</sup> / <sub>8</sub>	13 <sup>3</sup> / <sub>8</sub>	Air	50 CFM @ 80 psi	Air Pilot	M & V	<b>JAR10033</b>
150	26	39 <sup>1</sup> / <sub>8</sub>	18 <sup>1</sup> / <sub>8</sub>	Electric	25 amps	Manual	M	<b>JEM15026</b>
150	33	46 <sup>1</sup> / <sub>8</sub>	18 <sup>1</sup> / <sub>8</sub>	Air	50 CFM @ 80 psi	Manual	M	<b>JAM15033</b>