

# POW'R-RISER II RAIL CAR JACK

# Maintenance Jacks

- 60 & 100 ton capacities to handle the toughest jobs.
- Runs on air or 115VAC 20 amp or 230VAC 10 amp supply.
- 3 position handle for the easiest tilt back and rolling.
- Both electric & pneumatic models are fitted with a remote (12 volt or air pilot) pendant for operator safety.
- 4" / 102mm ground clearance for clearing rail and rough terrain.
- All Pow'r-Riser II® comply with ASME/ANSI B30.1 Specs.
- Only 24" / 610mm wide/fits in tight spots.
- Easy to change external filter minimizes down time.
- Rugged, fully enclosed frame; no exposed fittings or hoses.
- Sup'r-Stack™ extensions allow one jack to clear the pin on every style car.
- Equipped with a pilot-operated check valve which hydraulically locks the load in place to prevent accidental lowering.
- Optional mechanical lock rings for fail safe holding.

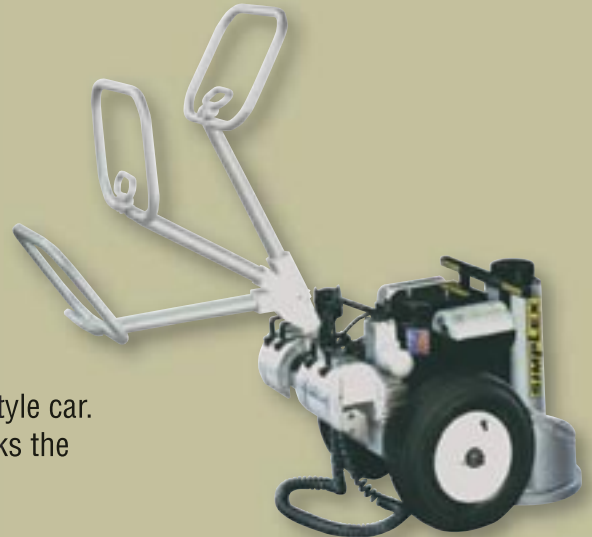

Model Number	Cap. (tons)	Min. Height		Stroke		Motor	Max. Additional Stack Ht. Using Optl. Ext. System		Control Valve	Power Source	Noise Level (Db)	Weight					
		(in)	(mm)	(in)	(mm)		(in)	(mm)				(lbs)	(Kg)				
JA6024	60	24	610	14	356	Air	32*	812,8*	Manual	Air Motor 50 cfm 80 psi 1,4 m³ 5,5 bar	89	390	177,3				
JA6037		37	940	27	686		11	279,4				600	272,7				
JE6024***		24	610	14	356	Electric	32*	812,8*		115 VAC / 230VAC 50/60 Hz 20 amps	80	390	177,3				
JE6037							37	940				27	686	11	279,4	600	272,7
JA10026	100	26	660	16	406	Air	21**	533,4**		Remote 12' / 3,7m Pendant	Air Motor 50 cfm 80 psi 1,4 m³ 5,5 bar	89	510	231,8			
JA10037		37	940	27	686		11	279,4					600	272,7			
JAS10026		26	660	16	406		21**	533,4**					510	231,8			
JAS10037		37	940	27	686		11	279,4					600	272,7			
JE10026		26	660	16	406	Electric	21**	533,4**	Manual	115 VAC / 230VAC 50/60Hz 20 amps	80	510	231,8				
JE10037							37	940				27	686	11	279,4	600	272,7
JEB10026							26	660				16	406	21**	533,4**	530	240,9
JEB10037							37	940				27	686	11	279,4	620	281,8

For 230 VAC add an "A" to the end of the model number.

\* Based on (1) 18" / 457,2mm and (1) 11" / 279,4mm extension and (1) 3" / 76,2mm spacer.

\*\*Based on (1) 18" / 457,2mm extension and (1) 3" / 76,2mm spacer.

WARNING: Any two extensions may be stacked for railcar lifting. For loads over 60 tons or strokes over 14" / 355,6mm only 1 extension and 1 spacer can be used.

\*\*\* JE6024 is ideal for most car shop work.

Model Number	"A"		"B"		"C"		"D"	
	(in)	(mm)	(in)	(mm)	(in)	(mm)	(in)	(mm)
JE6024	24	610	6.38	162	14	356	4	102
JE6037	37	940						
JE10026	26	660	7	178	18	457		
JE10037	37	940						

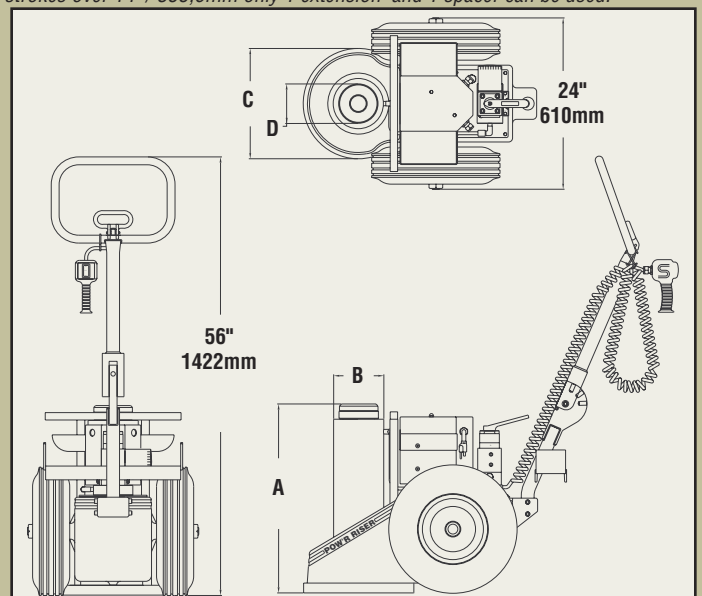

# POW'R-RISER II & TRUCK JACK ACCESSORIES

# Maintenance Jacks

**ONE JACK FOR ALL CARS FROM INTERMODAL TO HIGH HOPPER WITH 28 DIFFERENT HEIGHTS IN BETWEEN. The Simplex JE6024 & WJ60 60 Ton, When Either is Used With Sup'r-Stack™ Model #ES6024 Extension Set and Model #JS4 Spacer Set, Can Handle All Cars Without Blocking.**

**INDIVIDUAL SUP'R-STACK™ EXTENSIONS**  
( Use one extension & one spacer only for loads over 60 tons.)

<b>JE18</b> 18" 457,2mm	<b>JE14</b> 14" 355,6mm	<b>JE11</b> 11" 279,4mm	<b>JE9</b> 9" 228,6mm	<b>JE7</b> 7" 177,8mm	<b>JE5</b> 5" 127mm
-------------------------------	-------------------------------	-------------------------------	-----------------------------	-----------------------------	---------------------------

## ES6024 Railcar Extension Set

Model Number	Extender Description	
	(in)	(mm)
<b>JE5</b>	5	127
<b>JE7</b>	7	177,8
<b>JE11</b>	11	279,4
<b>JE18</b>	18	457,2

## SPACER SET - JS4

Never exceed 3" / 76,2mm in total spacer height.

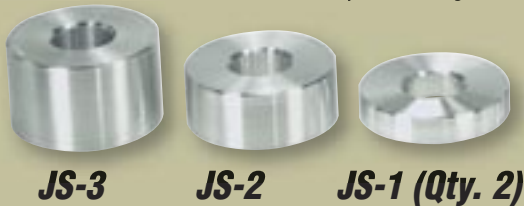

Fine tune your extension stack height by adding 1" / 25,4mm, 2" / 50,8mm or 3" / 76,2mm spacer.

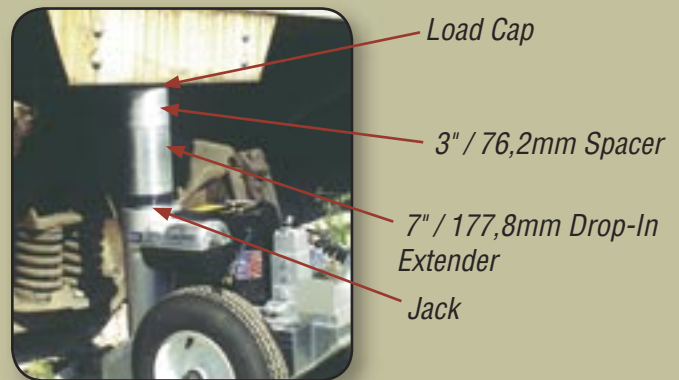

## LOCKING U-RING SETS

**60 & 100 Ton U-Rings**

<b>JU110</b> 10" 254mm	<b>JU14</b> 4.25" 107,9mm	<b>JU13</b> 3" 76,2mm	<b>JU11</b> 1" 25,4mm
------------------------------	---------------------------------	-----------------------------	-----------------------------

**Locking U-Rings are for Pow'r-Riser use only.**

**For a FREE Videotape On The Pow'r-Riser II Please Contact Simplex**



**Email Simplex at sales@tksimplex.com**

Model Number	Models Used On	Contains
<b>JUS126</b>	60 Ton 24" / 610mm - 100 Ton 26" / 660mm	(2) JU11 - 1" / 25,4mm, (1) JU13 - 3" / 76,2mm, (2) JU14 - 4.25" / 107,9mm
<b>JUS137</b>	60 & 100 Ton 37" / 940mm	(2) JU11 - 1" / 25,4mm, (1) JU13 - 3" / 76,2mm, (2) JU14 - 4.25" / 107,9mm, (1) JU10 - 10" / 254mm