

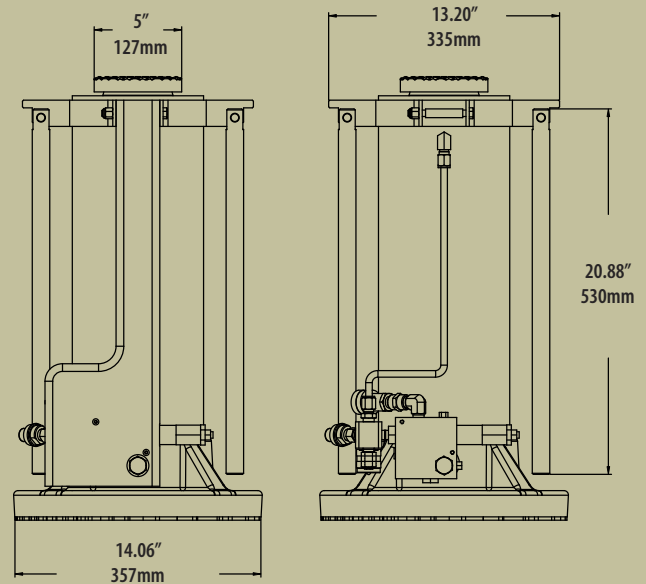

- Two 60 ton capacity jacks are used for track side emergency rail car repair.
- Jacks operate with existing outboard low pressure hydraulics running at 4,250 psi @ 60 tons.
- Lightweight jacks, with long swing arms allow for easy transport and placement of jacking units.
- Optional extensions and spacers available providing the WJ60 the ability of fitting under any rail car currently in service.



Model Number	Capacity (tons)	Stroke		Minimum Height		Extended Height		Effective Area		Oil Capacity Required		Operating Pressure @ Capacity		Weight	
		(in)	(mm)	(in)	(mm)	(in)	(mm)	sq. (in)	(cm ²)	(cu. in)	(cm ³)	(psi)	bar	(lbs)	(Kg)
WJ60	60	16.2	411,5	25.35	644	41.52	1055	28.27	182,4	22	360,6	4,250	293,3	185	84,1